

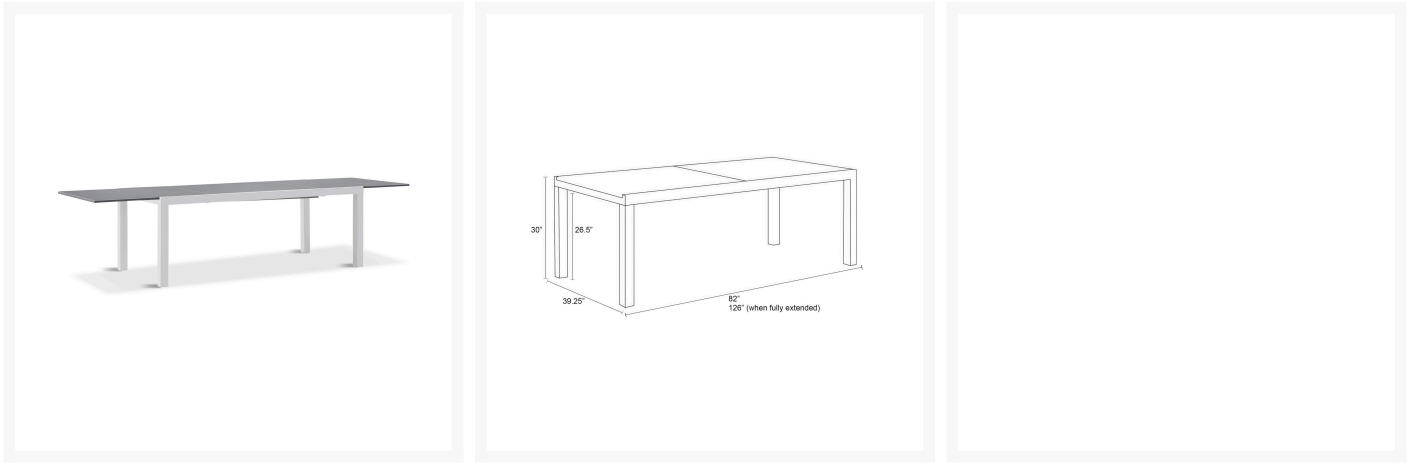

Product Images





Short Description

Spread Extendable Dining Table - White/Concrete HL-SP-WT-EXTDT-CON by Harmonia Living

Description

The Spread Extendable Dining Table - White/Concrete (HL-SP-WT-EXTDT-CON) by Harmonia Living will have you relaxing and enjoying good food and great company in your outdoor living space. Its fully-welded aluminum frames are treated with a powder-coated finish to ensure lasting performance across the seasons. Al-Stone is made from rust-proof aluminum with a heat and vacuum applied laminate that is incredibly realistic and scratch resistant. The table features one extension leaf that rotates into place during use or for easy storage under the table when not in use, and can easily be operated by one person. This patio dining table seats up to 12 when extended and 8 when not extended making it a flexible outdoor dining table for entertaining. Harmonia Living can be tailored to both Residential and Commercial settings and is committed to delivering exceptional furnishings to your outdoor space.

Includes

- One (1) Spread Extendable Dining Table - White/Concrete HL-SP-WT-EXTDT-CON

Dimensions

- 82 - 126"W x 39.25"D x 30"H (110 lbs.)
- Frame Height: 30"
- Under Table Height: 26.5

Features

- Durable, rust proof frames made from thick gauge aluminum with a high-quality powder coated finish that is appropriate for residential and commercial settings.
- Scratch resistant proprietary Al-Stone top with a concrete look.
- Easy and durable extension mechanism, simply pull apart the table from both sides and flip the extension leaf into place where it will stay put with magnetic hardware.
- Plastic foot glides help to protect your patio from scratching and also to help keep the furniture protected from dirt or water that can accumulate on the patio.
- Assembly required.



Warranty

Harmonia Living's warranty covers manufacturing defects; normal wear and tear is not included. With a little bit of care, your furniture will outlive the warranty for many years.

- Aluminum Frame: Harmonia Living extends a 3-year residential / 1-year commercial warranty against defects in workmanship and materials that cause structural failure

Care and Maintenance

Frame: Simply hose off or wipe down your frame to clean it! Avoid using harsh cleaners, brushes, or power washers, which could damage the finish. Take extra care when placing your furniture in humid or coastal settings; accumulation of salts and other debris can cause damage to your frame.

Disclaimer: Recommended for use only under covered patios, or if placed in direct sun, must be covered with protective cover to prevent fading. Covers & Storage: When not in use, we recommend using a protective cover with your furniture. During harsh weather and extreme temperatures, we recommend storing the cushions in a shed or garage and covering the frames with protective covers. If you store the frames indoors during the winter, avoid storing them upside down, which can trap moisture. If placed in direct sun, must be covered with a protective cover to prevent fading when not in use. In areas with harsh winter climates, cover the frames to prevent damage.

About the Manufacturer

Harmonia Living - an integration of beauty, function and durability. For over 15 years, Harmonia Living has strived to represent versatility and unparalleled value in every collection it designs and manufactures. Originally conceived from a vision to integrate elegant, high-end styles with approachable prices, Harmonia Living has grown from a small company based in San Diego, California to one that services the contiguous United States. Harmonia Living is committed to delivering outstanding service and exceptional indoor and outdoor furnishings to bring people together.

Additional Information

SKU	HL-SP-WT-EXTDT-CON
Brand	Harmonia Living
Ships Out Estimate	3 - 5 Business Days
Residential Warranty	Frame: 3 Years Finish: 1 Year

Spread Extendable Dining Table - White/Concrete HL-SP-WT-EXTDT-CON by Harmonia Living

was
\$2,020.00 Special
Price
\$1,439.00

