

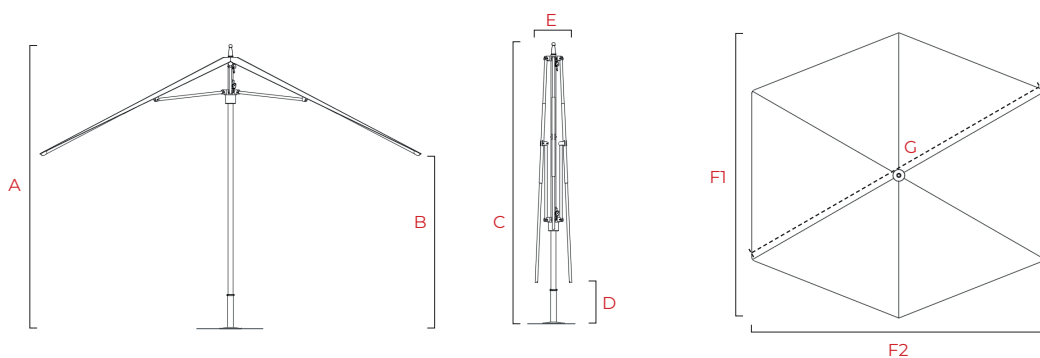

PRODUCT SPECIFICATIONS

OCEAN MASTER M1 POLYNESIAN



SHAPES	HEXAGON	
SIZES (ft/cm)	8.5 / 260	
A (in/cm)	MAST HEIGHT (open)	85 / 216
B (in/cm)	CANOPY CLEARANCE	51 / 130
C (in/cm)	MAST HEIGHT (closed)	85 / 216
D (in/cm)	TABLE CLEARANCE	12 / 31
E (in/cm)	PARASOL WIDTH (closed)	11 / 28
F (in/cm)	FLAT TO FLAT	F1: 110 / 280 F2: 113 / 287
G (in/cm)	POINT TO POINT	131 / 333

Dimension Tolerances $\pm 2'' / 5\text{cm}$. Dimensions shown are rounded to the nearest inch/cm and correspond to indicated lift system. Please check our 2D CAD-files for exact dimensions. Options are subject to change without notice.