

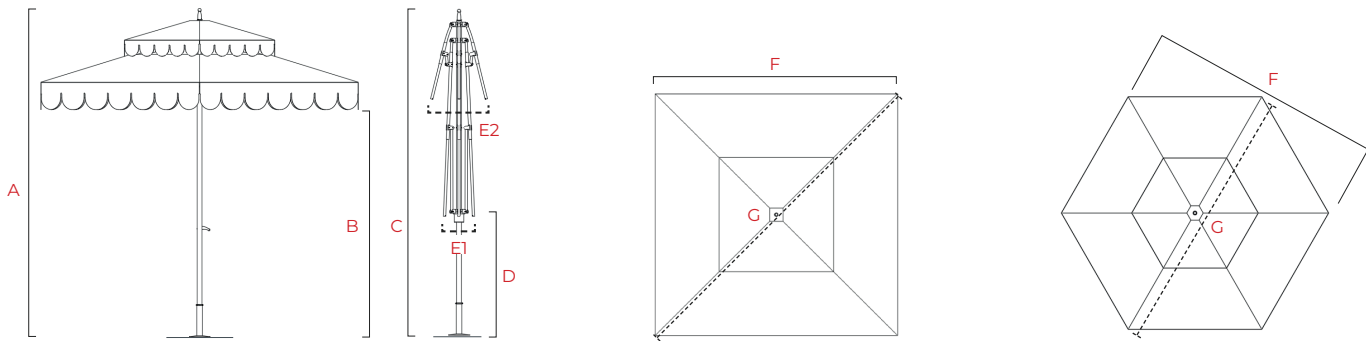

PRODUCT SPECIFICATIONS

OCEAN MASTER M1 CUPOLA



SHAPES		SQUARE		HEXAGON	
SIZES (ft/cm)		8.5 / 260	10.0 / 305	8.5 / 260	10.0 / 305
<b>A</b> (in/cm)	MAST HEIGHT (open)	105 / 267	108 / 274	103 / 262	105 / 267
<b>B</b> (in/cm)	CANOPY CLEARANCE	67 / 169	72 / 183	71 / 181	72 / 183
<b>C</b> (in/cm)	MAST HEIGHT (closed)	105 / 267	123 / 312	103 / 262	105 / 267
<b>D</b> (in/cm)	TABLE CLEARANCE	24 / 60	30 / 77	38 / 96	34 / 86
<b>E</b> (in/cm)	PARASOL WIDTH (closed)	E1: 24 / 60 E2: 27 / 68	E1: 27 / 68 E2: 34 / 87	E1: 10 / 25 E2: 18 / 46	E1: 10 / 25 E2: 19 / 48
<b>F</b> (in/cm)	FLAT TO FLAT	103 / 262	120 / 305	100 / 254	111 / 282
<b>G</b> (in/cm)	POINT TO POINT	145 / 370	170 / 432	115 / 292	128 / 325
(ft <sup>2</sup> /m <sup>2</sup> )	CANOPY AREA COVERAGE	73 / 6.8	100 / 9.3	59 / 5.5	74 / 6.9

Dimension Tolerances ± 2" / 5cm. Dimensions shown are rounded to the nearest inch/cm and correspond to indicated lift system. Please check our 2D CAD-files for exact dimensions. Options are subject to change without notice.