

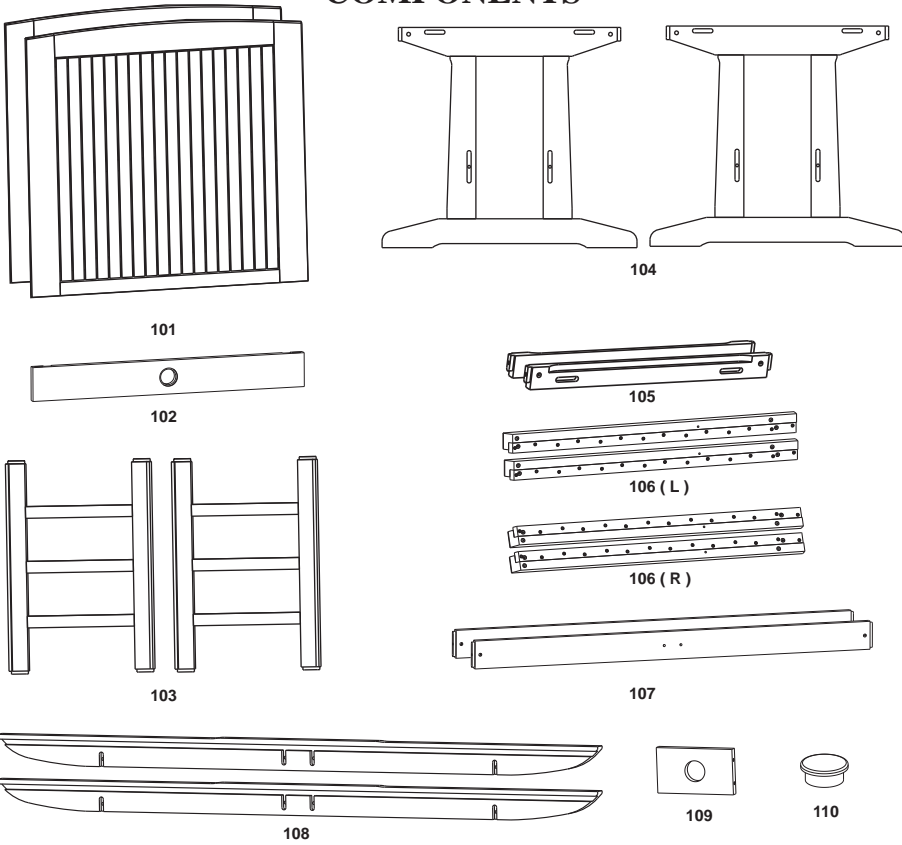







COMPONENTS

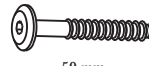

HARDWARE

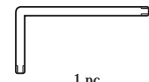
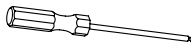
<p>A</p>  <p>M6 x 65 12 pcs.</p>	<p>B</p>  <p>M6 x 50 4 pcs.</p>	<p>C</p>  <p>10 x 15Mm 16 pc.</p>	<p>D</p>  <p>45 mm 20 pcs.</p>
<p>E</p>  <p>50 mm 4 pcs.</p>	<p>F</p>  <p>4 pcs.</p>	<p>H</p>  <p>1 pc.</p>	<p>I</p>  <p>1 pc.</p>
<p>J</p>  <p>1 pc.</p>	<p>K</p>  <p>M6 x 75 2 pcs.</p>		

TOOLS REQUIRED

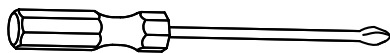

screwdriver

STEP 1

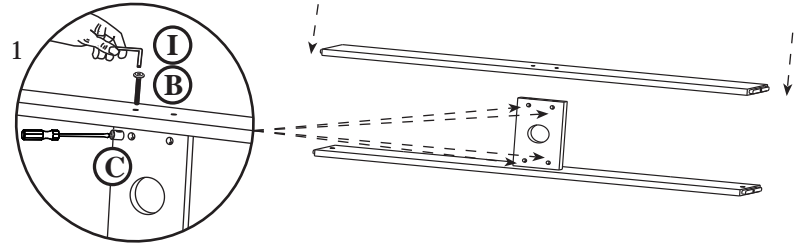

STEP 2

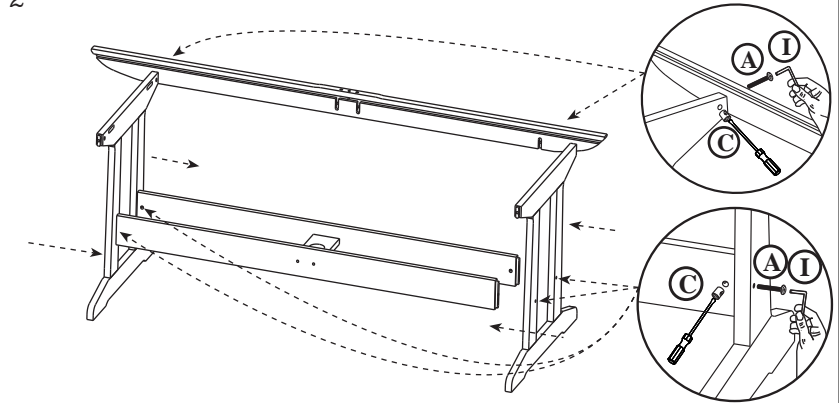

STEP 3

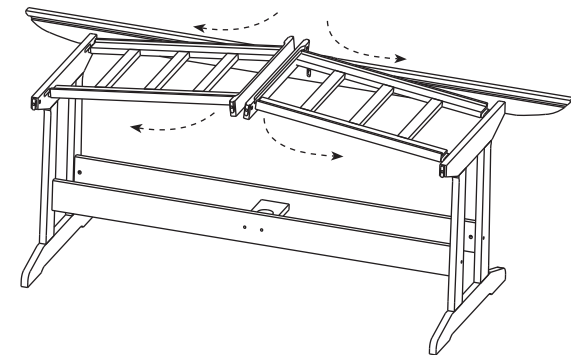

STEP 4

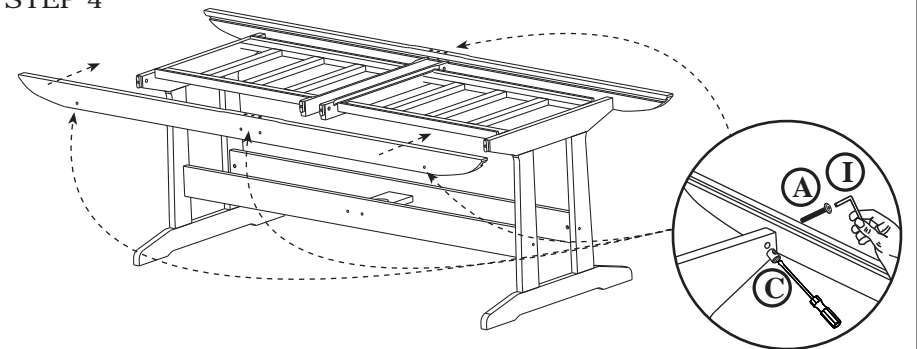

STEP 5

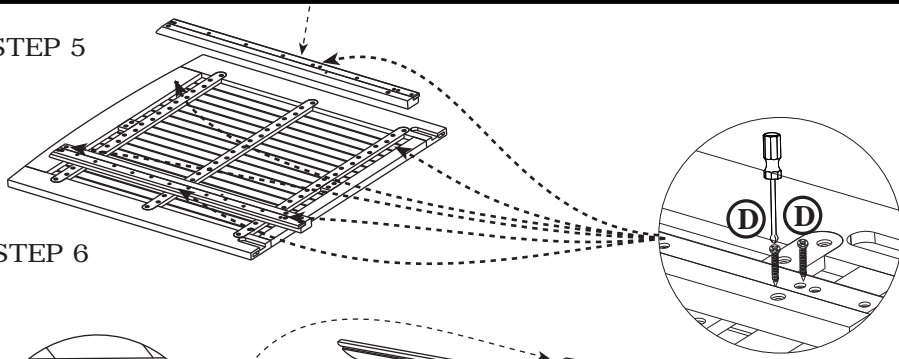

STEP 6

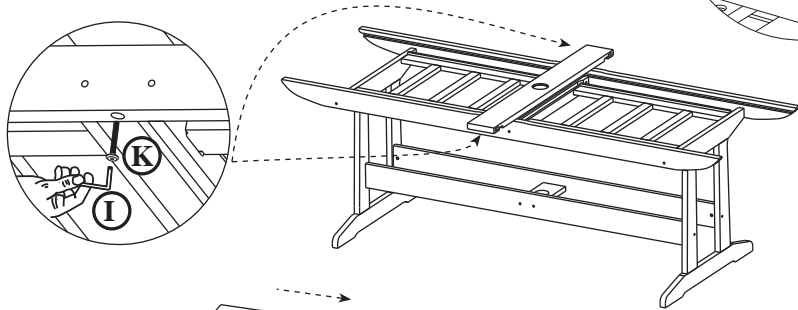

STEP 7

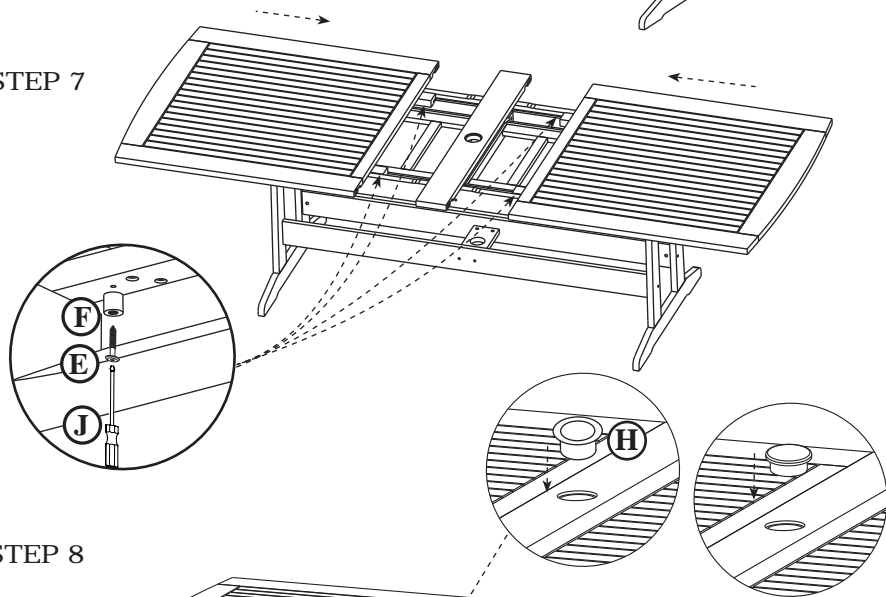

STEP 8

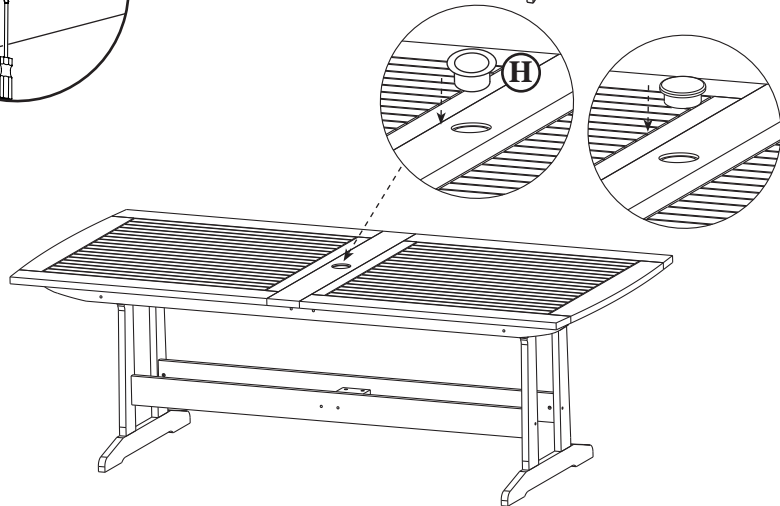

RICHMOND EXTENSION TABLE (#6494)

65253

Assembly Instructions

