

COMPONENTS

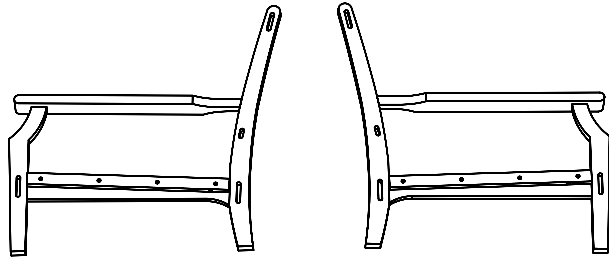

101 (R)

101 (L)

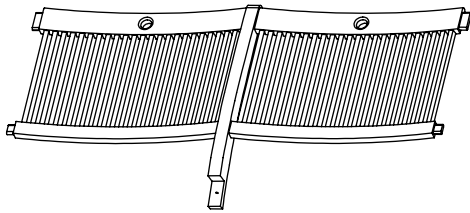



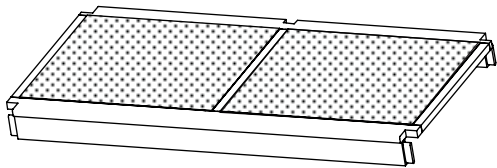

102



103

HARDWARE

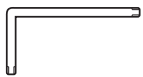
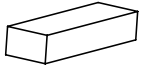
<p>A</p>  <p>M6 x 30 1 pcs.</p>	<p>B</p>  <p>M6 x 55 4 pcs.</p>	<p>C</p>  <p>32x8 mm 6 pcs.</p>	<p>D</p>  <p>42x8 mm 8 pcs.</p>
<p>E</p>  <p>1 pc.</p>	<p>F</p>  <p>1 pc.</p>		

TOOLS REQUIRED

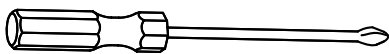

screwdriver

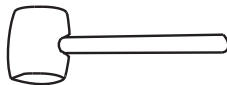

Hammer

STEP 1

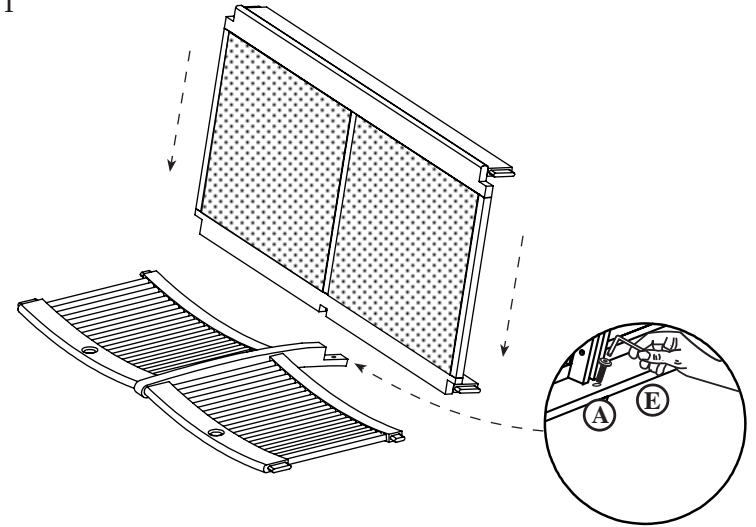

STEP 2

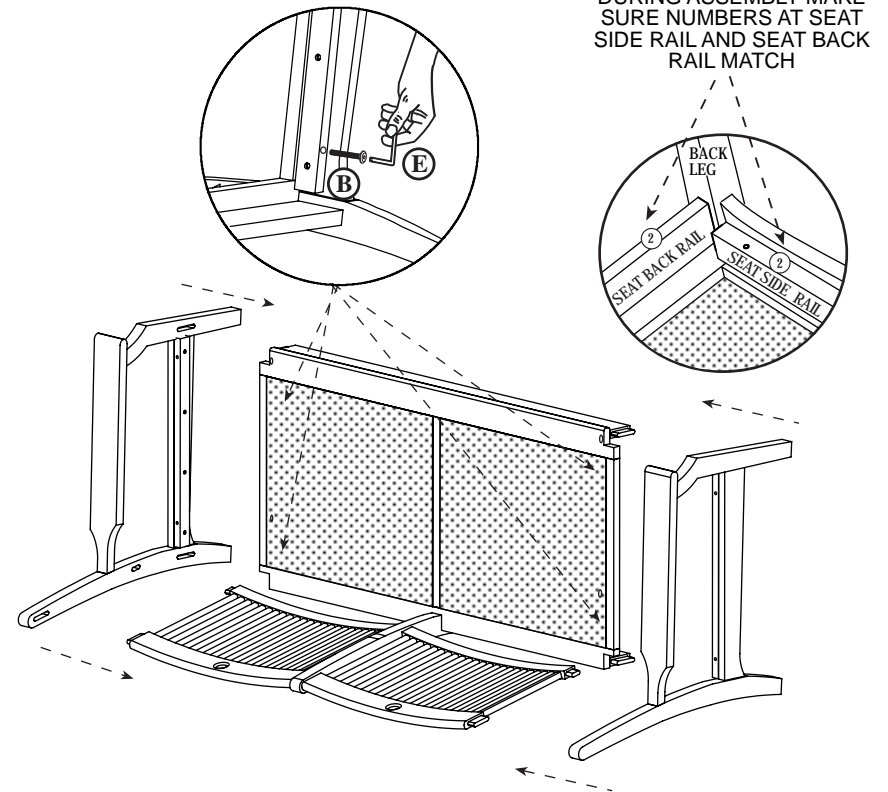

STEP 4

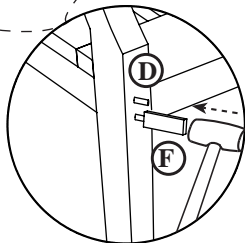
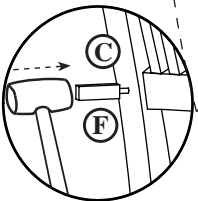
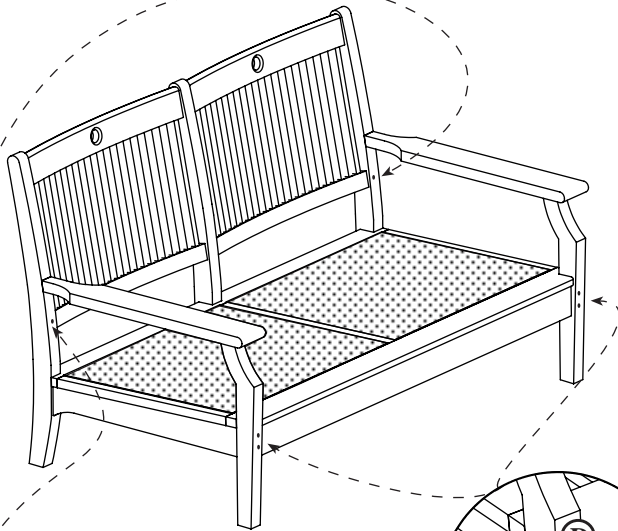
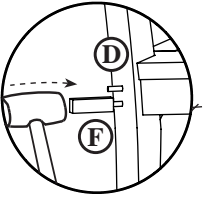
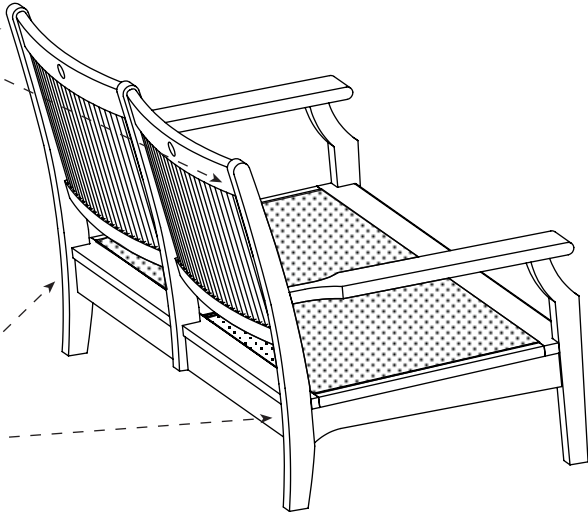
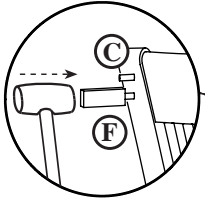

OPAL LOVE SEAT (#6559)

63420

Assembly Instructions

