

# COMPONENTS

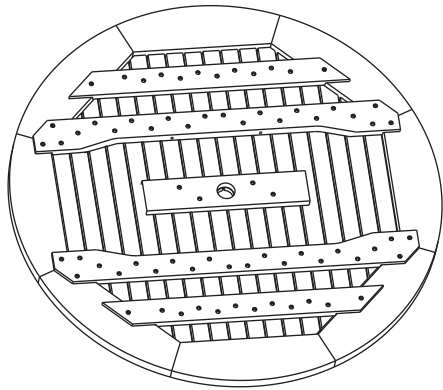

101

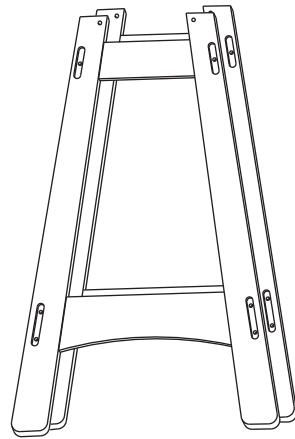

102

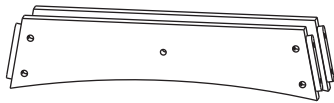

103

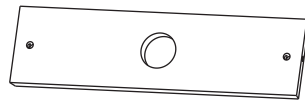

104

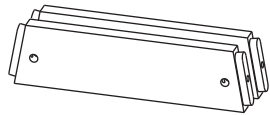

105



106

## HARDWARE

<p>A</p> <p>M6 x 65 mm 12 pcs.</p>	<p>B</p> <p>M6 x 50 mm 2 pcs.</p>	<p>C</p> <p>50 mm 4 pcs.</p>	<p>D</p> <p>14 pcs.</p>
<p>E</p> <p>1 pc.</p>	<p>F</p> <p>1 pc.</p>		

## TOOLS REQUIRED

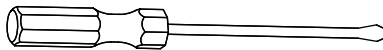

flat head screwdriver

### STEP 1

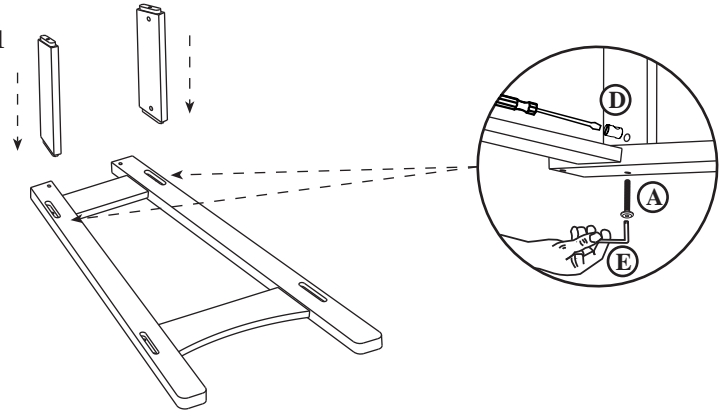

### STEP 2

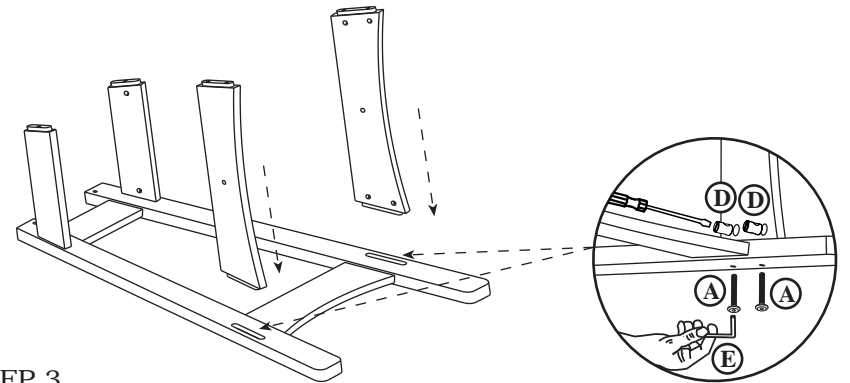

### STEP 3

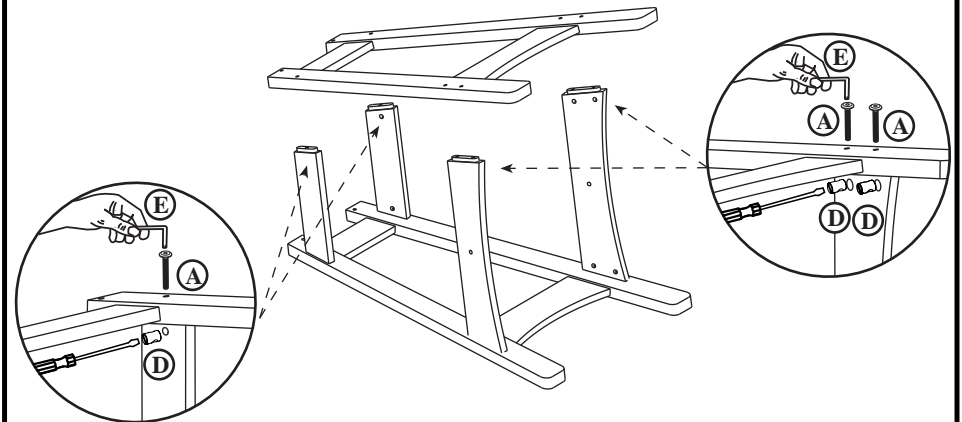

STEP 4

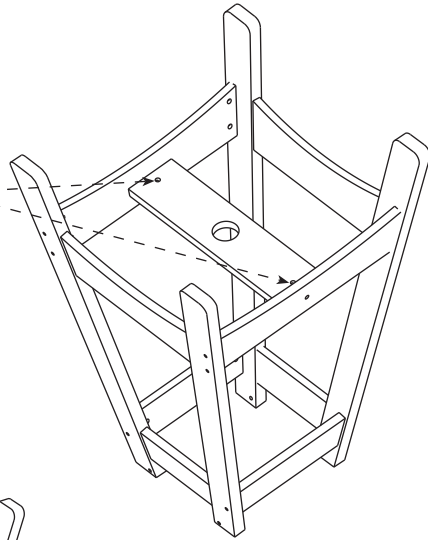
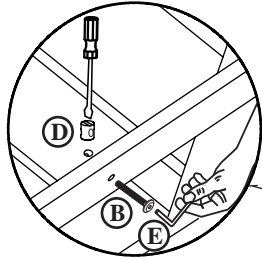

STEP 5

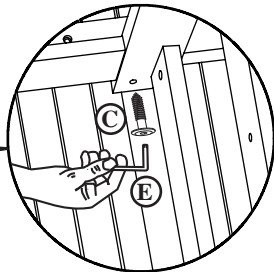
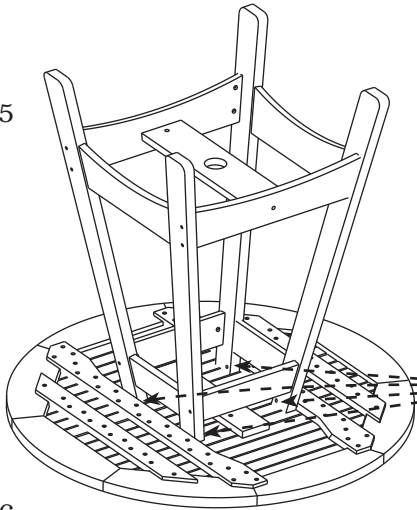

STEP 6

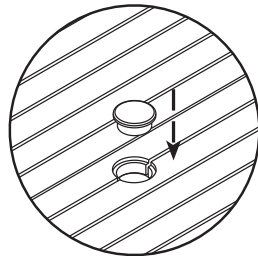
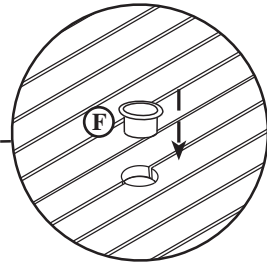

# CAPRI HI DINING TABLE (#6424)

# 62220

## Assembly Instructions

