

DEX Seating

(140 Armless)

(141 Left Arm)

(142 Right Arm)

(143 Club Chair)



SEASIDE CASUAL

ASSEMBLY INSTRUCTIONS

1

PLEASE READ INSTRUCTIONS COMPLETELY BEFORE BEGINNING.

Carefully remove contents from box. Make sure that all parts and hardware are included using the Parts List below.

Tools Required: 4mm Allen Wrench (included); #2 Phillips Head Screwdriver; Rubber Mallet

Back Assembly

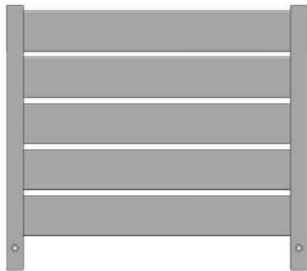

x 1

Seat Assembly

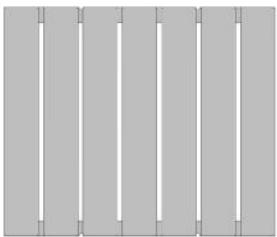

x 1

Front Apron



x 1

Rear Apron



x 1

Left Front Leg Assembly



140 x 0
141 x 1
142 x 0
143 x 1

Right Front Leg Assembly



140 x 0
141 x 0
142 x 1
143 x 1

Left Armless Side Assembly

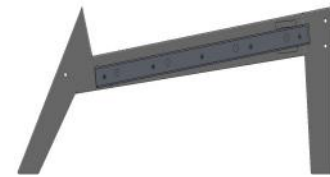

140 x 1
141 x 0
142 x 1
143 x 0

Right Armless Side Assembly

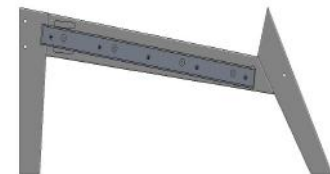

140 x 1
141 x 1
142 x 0
143 x 0

Left Armed Side Assembly

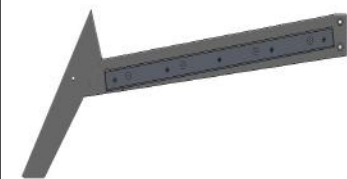

140 x 0
141 x 1
142 x 0
143 x 1

Right Armed Side Assembly



140 x 0
141 x 0
142 x 1
143 x 1

WARRANTY QUESTIONS OR COMMENTS PLEASE CALL TOLL FREE AT 1-800-809-3114

Parts List Continued:

4mm Allen Wrench

Actual Size



Part Code: 4MMALLEN

x 1

1-3/4" Phillips Head Screw

Actual Size



Part Code: 316-8X1-3/4PFDS

x 10

50mm Hex Lag

Actual Size



Part Code: 316-1/4-10-50HL

x 12

3/4" Phillips Pan Head Screw

Actual Size



Part Code: 316-8X3/4PTS

x 10

5/8" tap®



x 10

2

ATTACH SIDE TO FRONT LEG ASSEMBLY (ARMED VERSIONS ONLY)

Align Front Leg Assembly with corresponding Side Assembly as shown. Secure using (2) 50mm Hex Lags thru counter-bores in Side Assembly into pilot holes in Front Leg.

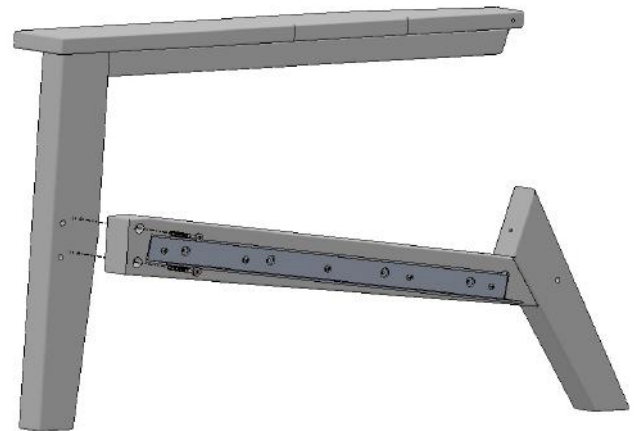

3

ATTACH APRONS TO SIDE ASSEMBLIES

Align Front and Rear Apron (Rear Apron has pocket for screw) as shown. Secure using (6) 50mm Hex Lags thru counter-bored holes in Legs into pilot holes in Aprons. Secure Rear Apron using (2) 1-3/4" Phillips Head Screws thru pockets into Rear Legs. Plug Holes with 5/8" taps®.

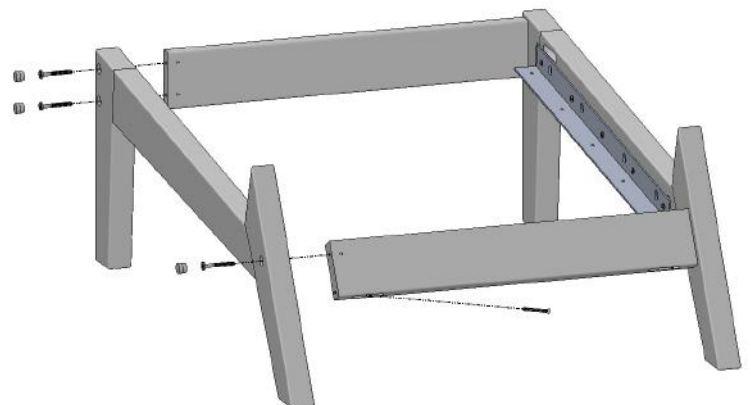

4

ATTACH BACK ASSEMBLY

Align Back Assembly as shown. Secure using (4) 50mm Hex Lags thru counter-bored holes in Side Aprons thru pilot holes in Back. And thru counter-bores in Back Assembly into pilot holes in Rear Legs. Plug Holes in Back with 5/8" taps®.

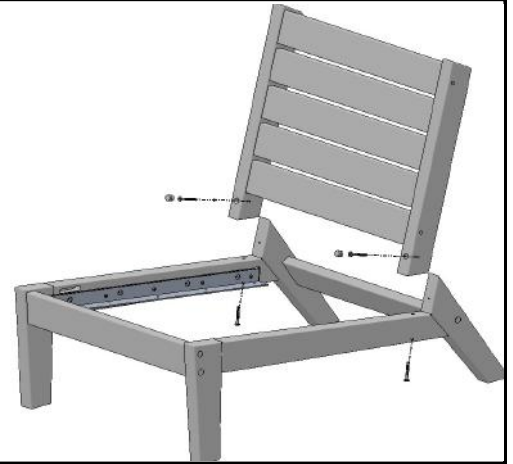

5

ATTACH SEAT ASSEMBLY

Secure Seat Assembly using (8) 1-3/4" Phillips Head Screws thru counter-bores in Seat into Pilot holes in Side Assembly. Then use (10) 3/4" Pan Head Screws thru Aluminum into bottom of Seat Support.



6

ATTACH ARMS TO BACK (ARMED VERSIONS ONLY)

Attach rear of Arm to Back Assembly using (1 per Arm) 50mm Hex Lag thru counter-bore hole in rear of Back Assembly into pilot hole in rear of Arm. Plug hole with 5/8" tap®.

